



READ AND SAVE THESE INSTRUCTIONS

Installer: leave this guide with homeowner.

Register your product online at www.broan.ca/register.asp

EZ80C

EZ Fit

Ventilation Fan

INSTALLATION GUIDE

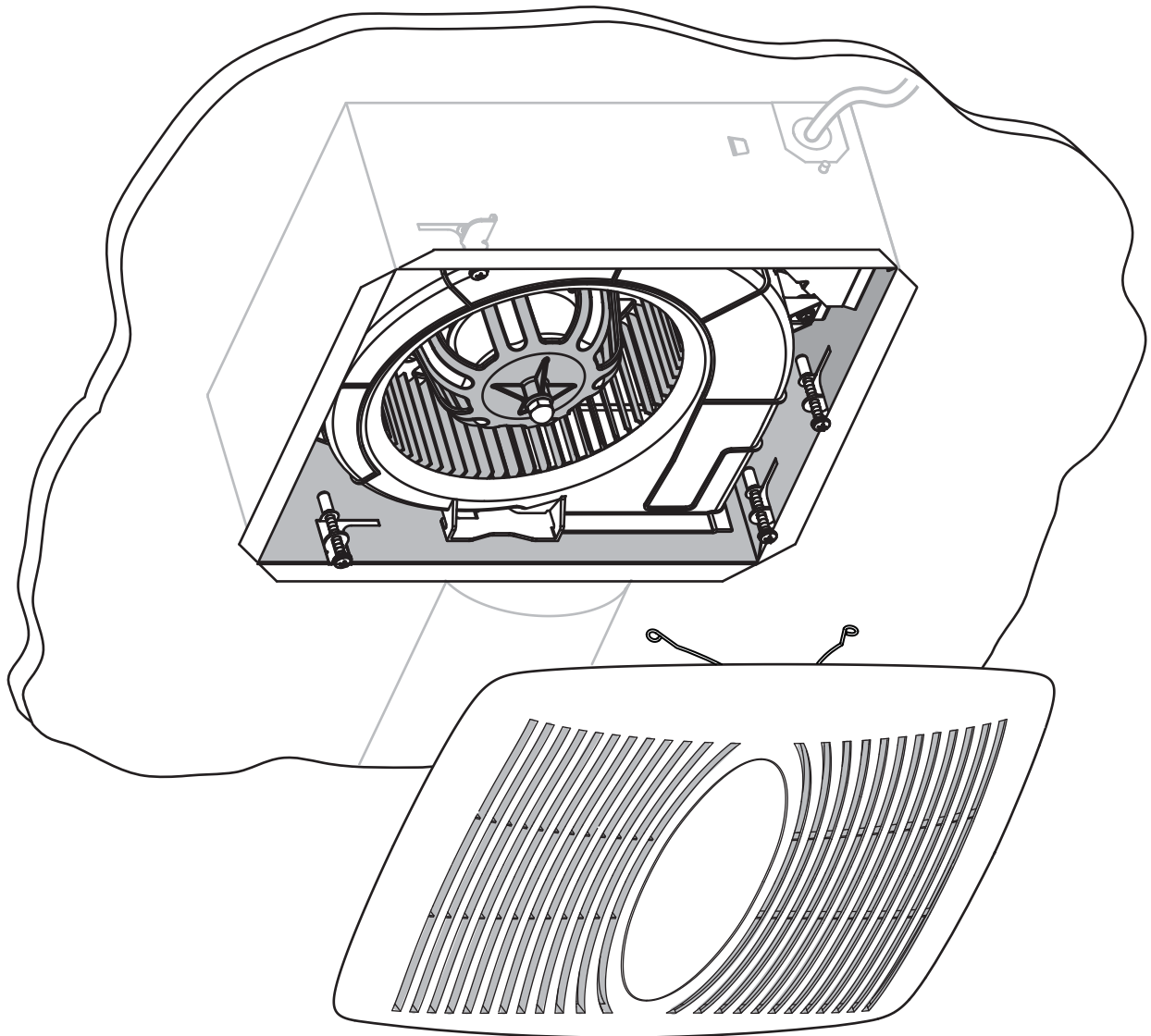

Easy installation

Table of Contents

| | |
|--|-----|
| Warnings and Cautions | 2 |
| Operation | 2 |
| Cleaning and Maintenance | 2 |
| Troubleshooting | 2 |
| Typical Installation | 2 |
| Installation - Replace an Existing Fan | 3-6 |
| Installation in New Construction | 7 |
| Service Parts | 8 |
| Warranty | 8 |

WARNING

TO REDUCE THE RISK OF FIRE, ELECTRIC SHOCK, OR INJURY TO PERSONS, OBSERVE THE FOLLOWING:

1. Use this unit only in the manner intended by the manufacturer. If you have questions, contact the manufacturer at the address or telephone number listed in the warranty.
2. Before servicing or cleaning unit, switch power off at service panel and lock the service disconnecting means to prevent power from being switched on accidentally. When the service disconnecting means cannot be locked, securely fasten a prominent warning device, such as a tag, to the service panel.
3. Installation work and electrical wiring must be done by a qualified person(s) in accordance with all applicable codes and standards, including fire-rated construction codes and standards.
4. Sufficient air is needed for proper combustion and exhausting of gases through the flue (chimney) of fuel burning equipment to prevent backdrafting. Follow the heating equipment manufacturer's guideline and safety standards such as those published by the National Fire Protection Association (NFPA), and the American Society for Heating, Refrigeration and Air Conditioning Engineers (ASHRAE), and the local code authorities.
5. When cutting or drilling into a ceiling, do not damage electrical wiring and other hidden utilities.
6. Ducted fans must always be vented to the outdoors.
7. Acceptable for use over a tub or shower (in the ceiling only) when connected to a GFCI (Ground Fault Circuit Interrupter) - protected branch circuit.
8. This unit must be grounded.

CAUTION

1. For general ventilating use only. Do not use to exhaust hazardous or explosive materials and vapors.
2. DO NOT install this unit onto an acoustic ceiling panel.
3. When installed in a sloped ceiling, the duct connector must point up.
4. To avoid motor bearing damage and noisy and/or unbalanced impellers, keep drywall spray, construction dust, etc. off power unit.
5. Please read specification label on product for further information and requirements.



Operation

To Operate Fan

Use an ON/OFF switch or speed control to operate this ventilator.

WARNING  Before servicing or cleaning unit, switch power off at service panel and lock the service disconnecting means to prevent power from being switched on accidentally. When the service disconnecting means cannot be locked, securely fasten a prominent warning device, such as a tag, to the service panel.

Cleaning and Maintenance

To Clean

For quiet and efficient operation, long life and attractive appearance, remove grille and vacuum interior of unit with a dusting brush attachment.

The motor is permanently lubricated and never needs oiling. If the motor bearings are making excessive or unusual noises, replace the motor.

Troubleshooting

Symptom: The fan does not run.

- Check for an open fuse or circuit breaker in the building's service panel.
- Check that the plug-in connection for the motor is seated firmly in place.
- Check that the blower wheel spins freely.

Symptom: The fan runs erratically.

- Check that the blower wheel is firmly attached to the motor shaft and both spin freely.

Symptom: The fan seems noisy.

- Check that the back draft damper in the fan's duct connector pivots freely. Screws used to attach the ducting to the duct connector may be preventing the damper from opening.
- Check that the back draft damper in the wall or roof cap pivots freely. These dampers are sometimes mistakenly painted shut or obstructed by bird and insect debris.

Typical Installation

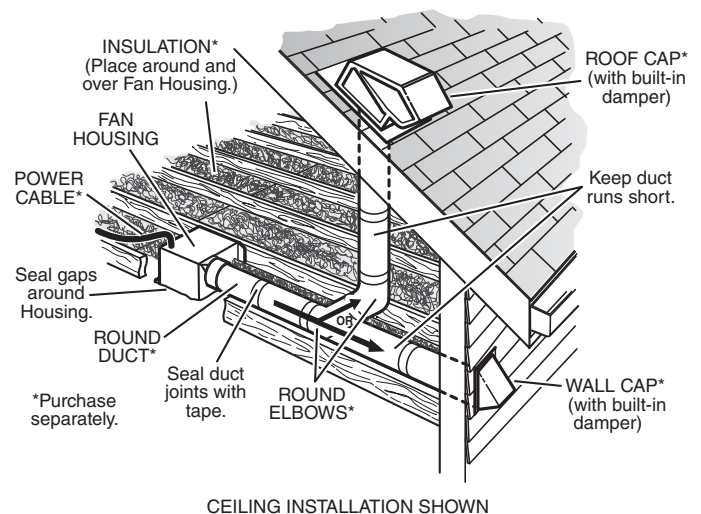

Installation - Replace an Existing Fan

Tools needed

- Phillips screwdriver (recommended)
- Hammer
- Safety glasses
- Pencil
- Tape Measure
- Drywall saw

Materials needed

- 4" round metal ducting recommended for best performance. Use of other ducting is acceptable but may impact performance.
- Roof cap or wall cap (built-in damper recommended)
- Tape to seal duct connections
- Drywall screws, sheet metal screws (optional)
- Electrical wiring and supplies per local code requirements

1 Remove from Packaging

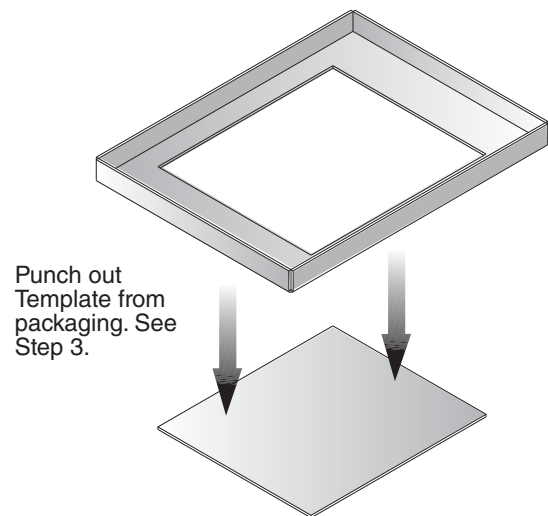
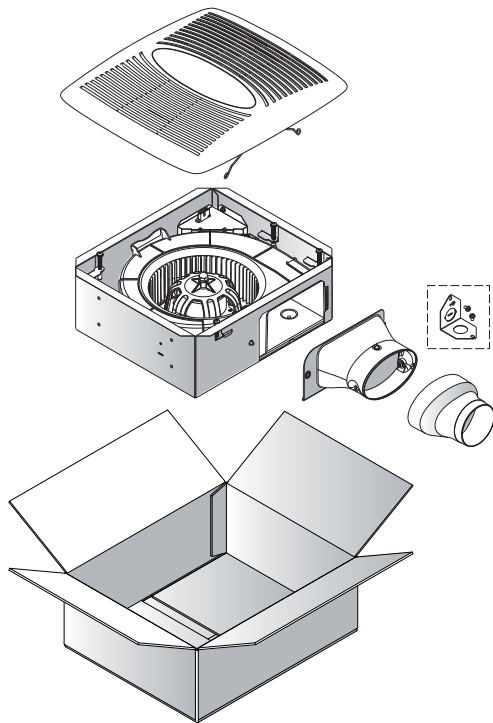

2 Prepare the Housing

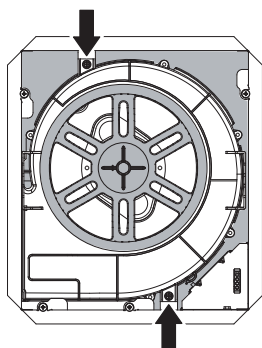

1 Loosen 2 blower screws.

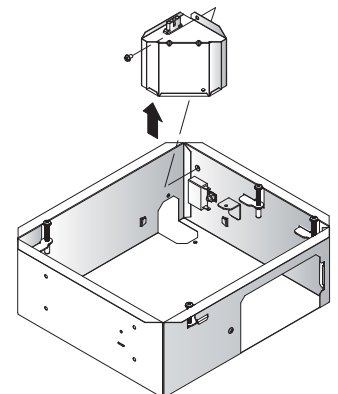
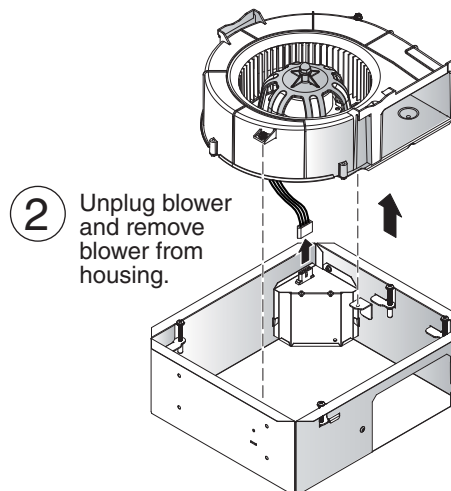

3 Remove wiring cover.

Installation - Replace an Existing Fan

3 Mark Ceiling Using Template

1 Make sure existing fan is no larger than 8" x 8 1/4".

2 Mark center line of existing fan on ceiling.

3 Position template over existing fan with arrow on center line.

4 Trace around outside of template with a pencil.

4 Cut Ceiling Opening & Remove Old Fan

1 Use a drywall saw to cut out ceiling material where marked.

2 Disconnect electrical wiring and ductwork - then remove existing fan.

WARNING
Be careful to avoid cutting through electrical wiring or ductwork.

Installation - Replace an Existing Fan

5 Install New Housing

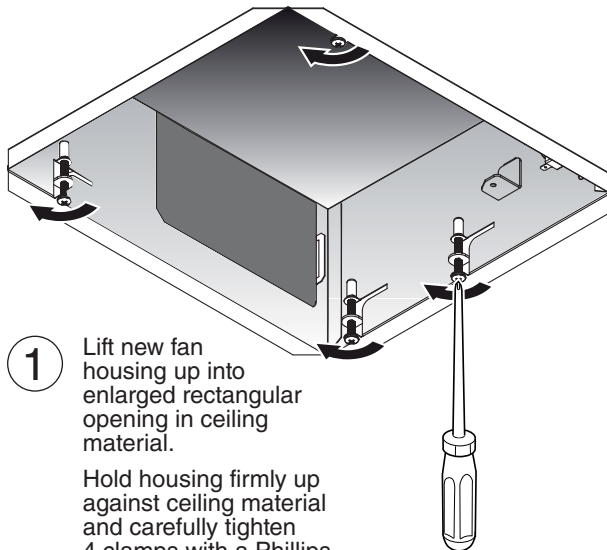

- 1 Lift new fan housing up into enlarged rectangular opening in ceiling material. Hold housing firmly up against ceiling material and carefully tighten 4 clamps with a Phillips screwdriver.

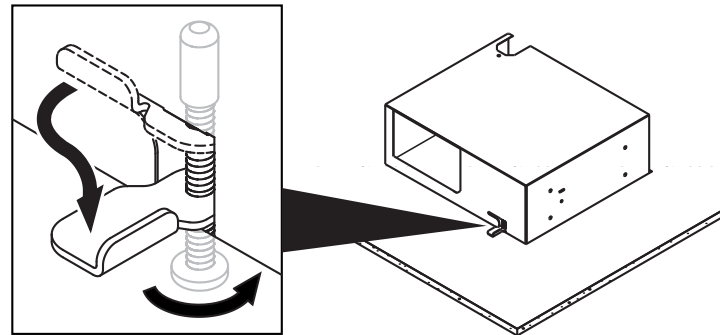

- 2 When turned clockwise (with a Phillips screwdriver), clamps will spin outward from housing and move downward on top of ceiling material to properly secure housing in place. Minimum ceiling thickness to be 1/2".

CAUTION: Do not overtighten clamps with a power driver. Ceiling material may become deformed and prevent proper installation.

6 Connect Ductwork

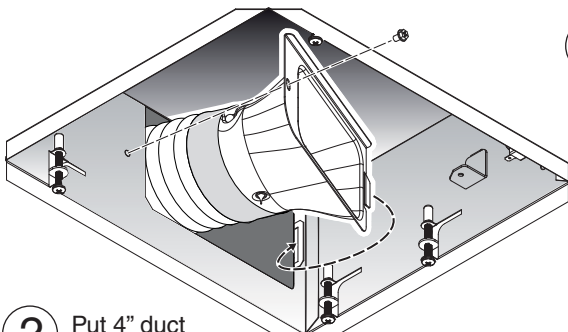

- 2 Put 4" duct connector into opening and fasten to housing with tab and screw provided.

- 1 Adjust 4" ductwork into housing and use duct tape to attach it to 4" duct connector. Rigid duct may have to be cut to fit prior to housing installation. For 3" ductwork, use the 4" to 3" reducer (provided). See below.

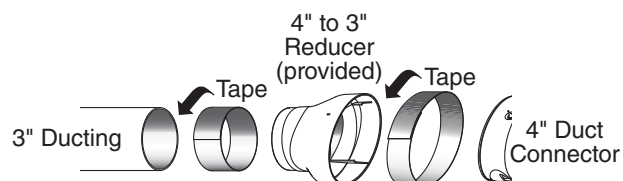

Installation - Replace an Existing Fan

7 Connect Electrical Wiring

WARNING  

TO REDUCE THE RISK OF FIRE, ELECTRIC SHOCK, OR INJURY TO PERSONS, OBSERVE THE FOLLOWING:

If unfamiliar with electrical wiring, secure the services of a qualified person to connect wiring according to all applicable codes and standards.

Connect house wiring to wiring plate with UL approved connector.

Connect wiring as shown in diagrams.

Attach wiring plate and wiring cover to inside of housing with screws provided.

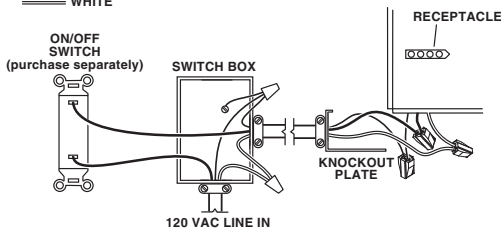
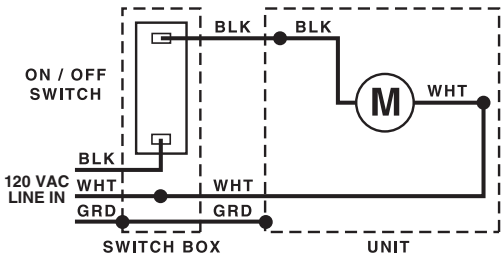
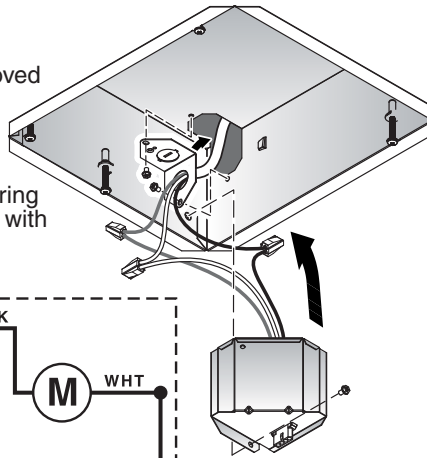

8 Replace Blower

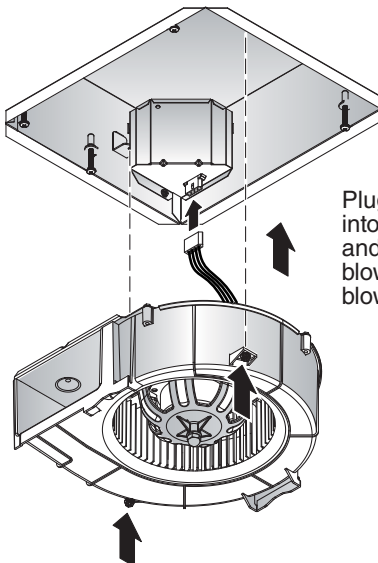

Plug blower into receptacle and re-install blower. Tighten blower screws.

9 Install Grille

1 Squeeze grille springs and insert into slots in blower.

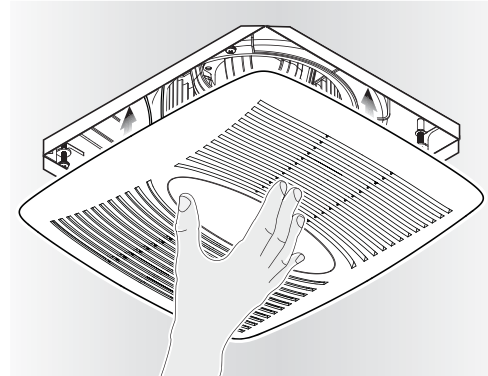
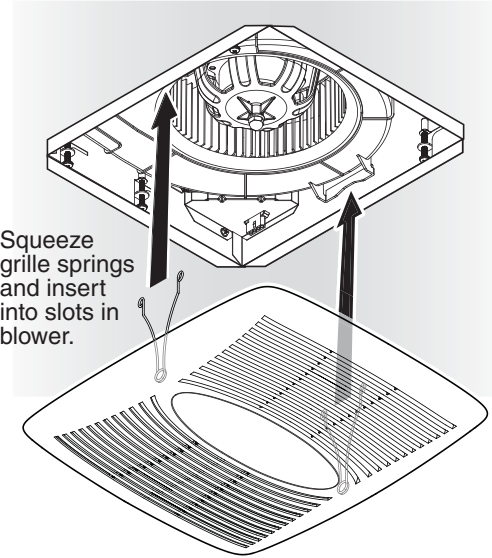

2 Push grille up against ceiling.

Installation in New Construction

1 Remove from Packaging (See Page 3)

2 Prepare the Housing (See Page 3)

3 Install Fan Housing & Connect Ductwork

1 Push 4" duct connector into opening and fasten to housing with tab and screw provided.

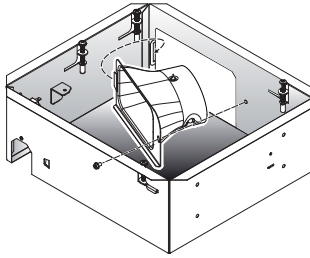

2 In new construction (before ceiling is finished):

Attach housing to 2" x 6" or greater ceiling joists. Use additional blocking as needed.

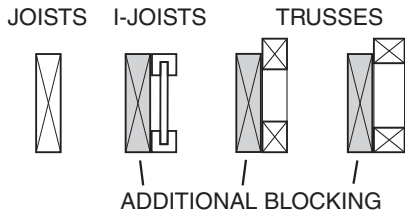

3 Position fan against ceiling framing with bottom edge of housing flush with finished ceiling.

Use 4 screws to attach housing to framing.

Optional for additional support: After ceiling is finished, rotate the tightening clamps as described in Step 5.

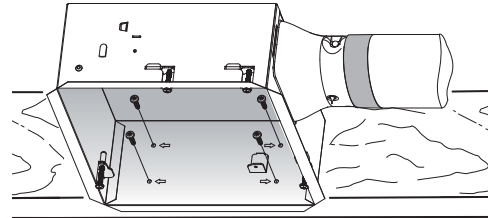

4 Use duct tape to connect 4" ductwork to 4" duct connector. For 3" ductwork, use the 4" to 3" reducer (provided). See below.

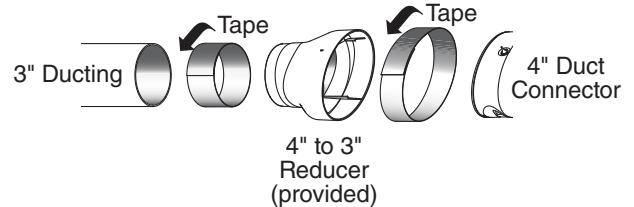

4 See "Connect Electrical Wiring" on Page 6.

5 See "Replace Blower" on Page 6.

6 See "Install Grille" on Page 6.

Service Parts

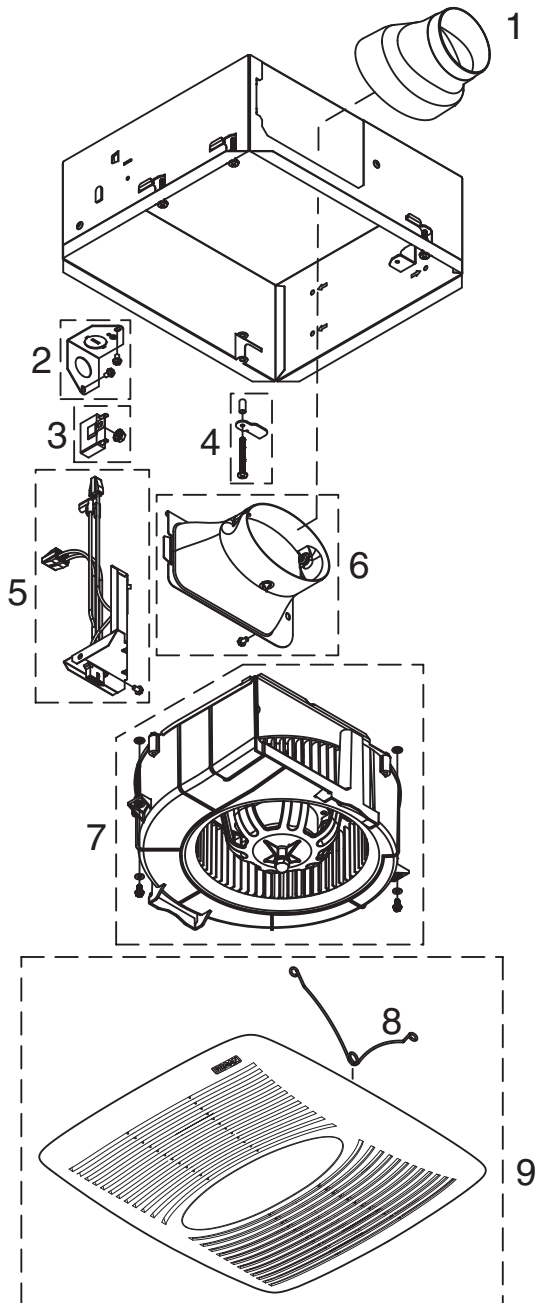

| Key No. | Part No. | Description |
|---------|----------|---|
| 1 | 79110158 | 4" to 3" Reducer |
| 2 | 97019326 | Wiring Plate |
| 3 | 77001297 | Capacitor |
| 4 | 77001447 | Tightening Clamps (includes 4 screws & clamps) |
| 5 | 97019006 | Wire Cover Assembly |
| 6 | 77001277 | Duct Connector Assembly |
| 7 | 97019349 | Blower Assembly |
| 8 | 79140014 | Grille Spring (2 included) |
| 9 | 97019325 | Grille Assembly (includes 2 grille springs) |

Order replacement parts by Part No., not by Key No.

Warranty

Limited Warranty

Warranty Period and Exclusions: Broan-NuTone Canada Inc. (the "Company") warrants to the original consumer purchaser of its product ("you") that the product (the "Product") will be free from material defects in the Product or its workmanship for a period of one (1) year from the date of original purchase.

The limited warranty period for any replacement parts provided by the Company and for any Products repaired or replaced under this limited warranty shall be the remainder of the original warranty period.

This warranty does not cover speed controls, fluorescent lamp starters, tubes, halogen and incandescent bulbs, fuses, filters, ducts, roof caps, wall caps and other accessories for ducting that may be purchased separately and installed with the Product. This warranty also does not cover (a) normal maintenance and service, (b) normal wear and tear, (c) any Products or parts which have been subject to misuse, abuse, abnormal usage, negligence, accident, improper or insufficient maintenance, storage or repair (other than repair by the Company), (d) damage caused by faulty installation, or installation or use contrary to recommendations or instructions, (e) any Product that has been moved from its original point of installation, (f) damage caused by environmental or natural elements, (g) damage in transit, (h) natural wear of finish, (i) Products in commercial or nonresidential use, or (j) damage caused by fire, flood or other act of God. This warranty covers only Products sold to original consumers in Canada by the Company or Canadian distributors authorized by the Company.

This warranty supersedes all prior warranties and is not transferable from the original consumer purchaser.

No Other Warranties: This Limited Warranty contains the Company's sole obligation and your sole remedy for defective products. The foregoing warranties are exclusive and in lieu of any other warranties, express or implied. **THE COMPANY DISCLAIMS AND EXCLUDES ALL OTHER EXPRESS WARRANTIES, AND DISCLAIMS AND EXCLUDES ALL WARRANTIES IMPLIED BY LAW, INCLUDING WITHOUT LIMITATION THOSE OF MERCHANTABILITY AND FITNESS FOR A PARTICULAR PURPOSE.**

To the extent that applicable law prohibits the exclusion of implied warranties, the duration of any applicable implied warranty is limited to the period specified for the express warranty above. Some provinces do not allow limitations on how long an implied warranty lasts, so the above limitation may not apply to you. Any oral or written description of the Product is for the sole purpose of identifying it and shall not be construed as an express warranty.

Whenever possible, each provision of this Limited Warranty shall be interpreted in such manner as to be effective and valid under applicable law, but if any provision is held to be prohibited or invalid, such provision shall be ineffective only to the extent of such prohibition or invalidity, without invalidating the remainder of such provision or the other remaining provisions of the Limited Warranty.

Remedy: During the applicable limited warranty period, the Company will, at its option, provide replacement parts for, or repair or replace, without charge, any Product or part thereof, to the extent the Company finds it to be covered by and in breach of this limited warranty under normal use and service. The Company will ship the repaired or replaced Product or replacement parts to you at no charge. You are responsible for all costs for removal, reinstallation and shipping, insurance or other freight charges incurred in the shipment of the Product or part to the Company. If you must send the Product or part to the Company, as instructed by the Company, you must properly pack the Product or part—the Company is not responsible for damage in transit. The Company reserves the right to utilize reconditioned, refurbished, repaired or remanufactured Products or parts in the warranty repair or replacement process. Such Products and parts will be comparable in function and performance to an original Product or part and warranted for the remainder of the original warranty period.

Exclusion of Damages: **THE COMPANY'S OBLIGATION TO PROVIDE REPLACEMENT PARTS, OR REPAIR OR REPLACE, AT THE COMPANY'S OPTION, SHALL BE YOUR SOLE AND EXCLUSIVE REMEDY UNDER THIS LIMITED WARRANTY AND THE COMPANY'S SOLE AND EXCLUSIVE OBLIGATION. THE COMPANY SHALL NOT BE LIABLE FOR INCIDENTAL, INDIRECT, CONSEQUENTIAL OR SPECIAL DAMAGES ARISING OUT OF OR IN CONNECTION WITH THE PRODUCT, ITS USE OR PERFORMANCE.**

Some provinces do not allow the exclusion or limitation of incidental or consequential damages, so the above limitation or exclusion may not apply to you. This warranty gives you specific legal rights, and you may also have other rights, which vary from province to another.

This warranty covers only replacement or repair of defective Products or parts thereof at the Company's main facility and does not include the cost of field service travel and living expenses.

Any assistance the Company provides to or procures for you outside the terms, limitations or exclusions of this limited warranty will not constitute a waiver of such terms, limitations or exclusions, nor will such assistance extend or revive the warranty.

The Company will not reimburse you for any expenses incurred by you in repairing or replacing any defective Product, except for those incurred with the Company's prior written permission.

How to Obtain Warranty Service: To qualify for warranty service, you must (a) notify the Company at the address or telephone number stated below within seven (7) days of discovering the covered defect, (b) give the model number and part identification and (c) describe the nature of any defect in the Product or part. At the time of requesting warranty service, you must present evidence of the original purchase date. If you cannot provide a copy of the original written limited warranty, then the terms of the Company's most current written limited warranty for your particular product will control. The most current limited written warranties for the Company's products can be found at www.broan.ca.

Broan-NuTone Canada Inc. 1140 Tristar Drive, Mississauga, ON www.broan.ca 877-896-1119